

# Installation and Maintenance Instructions

GNUMG  
351-5

Following the procedures detailed herein will ensure that the Expander System is installed correctly. It will also ensure that the assembly will be removable for access to the bushings/bearings or when other service is required on the pivot.

**IMPORTANT:** Do not install your Expander System until you have read and understood the information contained in these instructions.

FOR QUESTIONS CALL YOUR LOCAL DEALER.

## Section 1 Preparation

**1.1 CAUTION:** Prior to installation, ensure there are no existing structural damages (i.e. cracks, severely bent lug ears etc.) that would affect the alignment of the pivot lugs. If damage exists, it may result in the Expander System not functioning properly. Repair structural damages **BEFORE** proceeding with installation.

Double check the minimum and maximum wear points of the lug holes to ensure that you have purchased the correct size expansion sleeve for each side of the pin. Each expansion sleeve expands to a maximum of 2.0 mm (0.08 inch). If the maximum wear diameter of the lug hole is more than 2.0 mm (0.08 inch) larger than the diameter of the sleeve, contact your local dealer to order the appropriate oversize expansion sleeve.

MAX - MIN < 1.5 mm (0.06 inch)

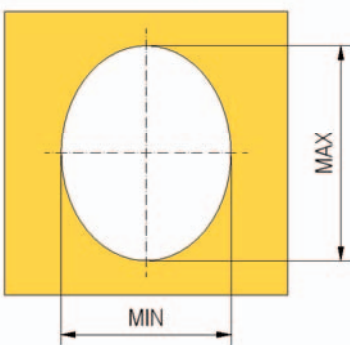

**IF YOU ATTEMPT TO INSTALL THE EXPANDER SYSTEM WITH IMPROPERLY SIZED EXPANSION SLEEVES, THE INSTALLATION WILL NOT BE SUCCESSFUL.**

**1.2** Visually inspect the bore surface of the mounting lugs. Remove any ridges or other irregularities.

If the lug hole has more than 1.5 mm (0.06 inch) difference between the minimum and maximum wear, the hole must be bored or ground out to a difference that is less than 1.5 mm (0.06 inch).

**FOR UNUSUAL WEAR CONDITIONS, CONTACT YOUR LOCAL DEALER FOR GUIDELINES.**

**1.3** If there are manufacturer installed steel bushings in the mounting lugs, it is recommended that they be removed and the appropriate oversize expansion sleeves should be used instead. This will eliminate any possible future wear between the bushing and mounting lug.

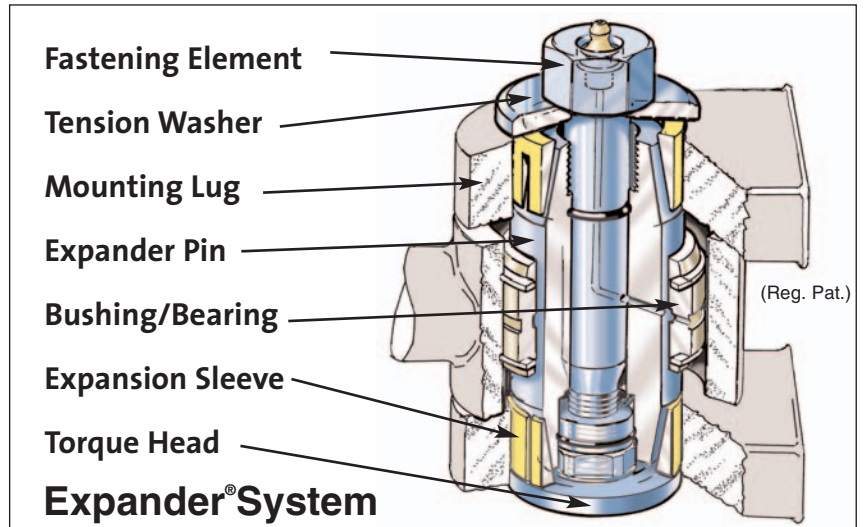

### DISMOUNTING TOOLS

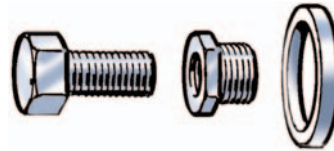

Dismounting Bolt • Adapter • Dismounting Ring

# Section 2 - Torque and Maintenance Intervals

## Torque Recommendation (Table 1)

### Bolts and Specialty Fasteners



UNIT	M12	M14	M16	M20	M24	M30	M36	M42
(Nm)	70	115	175	350	500	600	700	900
(Lbft)	52	85	129	258	369	443	516	664

### Nuts: Standard Height

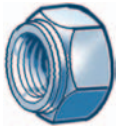

UNIT	M12	M14	M16	M20	M24	M30	M36	M42
(Nm)	65	115	175	250	350	500	600	700
(Lbft)	48	85	129	184	258	369	443	516

### Nuts: Low Height



UNIT	M12		M16	M20	M24	M30		
(Nm)	60		125	200	275	350		
(Lbft)	44		92	148	203	258		

### Spanner Nuts



UNIT	M17	M25	M35	M45	M55	M65	M75	M85
(Nm)	50	120	250	500	600	700	800	900
(Lbft)	37	89	184	369	443	516	590	664

**2.1 IMPORTANT: RE-TORQUE IS AN INTRICATE PART OF THE INSTALLATION AND CRUCIAL TO THE SUCCESS OF THE REPAIR.** Make sure to follow the torque schedule in Table 2.

**2.2 IMPORTANT: CHECK THE TORQUE AT REGULAR SERVICE INTERVALS.**

Apply appropriate torque according to Table 1. Tighten until the torque wrench "clicks out" on setting.

**2.3 IMPORTANT:** Proper greasing of your machine pivots are crucial for the functioning and durability of the Expander System. We strongly recommend using grease with 3-5% molybdenum disulfide, which allows much less wear and gives increased load carrying capability.

## Torque Schedule (Table 2)

<b>Hours of Operation</b>	<p>* When you re-torque and the wrench "clicks out" on setting without adding additional torque, you have successfully seated the expansion sleeves.</p> <p>If the expansion sleeves have not seated within one week of operation, call your local dealer for instructions.</p>
After 1 hour	
After 3 hours	
After 10 hours or 1 day *	
After 40 hours or 4 days *	

# Section 3 - Mounting/ Dismounting Tools

**3.1** Most Expander System assemblies do not need any special tools for installation and dismounting. If special tools are needed, they will be supplied with the assembly. If excessive force is needed or if space is limited, we recommend the use of Expander Mounting/Dismounting Tools (sold separately).

**CALL YOUR LOCAL DEALER FOR PRICING.**

## Section 4 - Installation

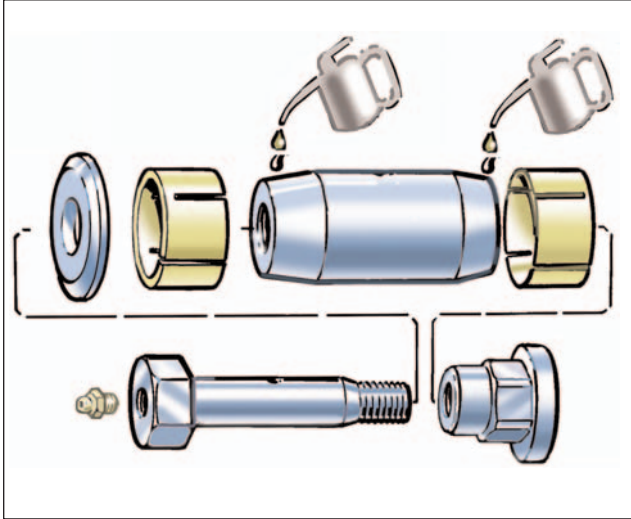

**4.1** Lubricate the Expander pin and the expansion sleeves with bearing grease for easy insertion.

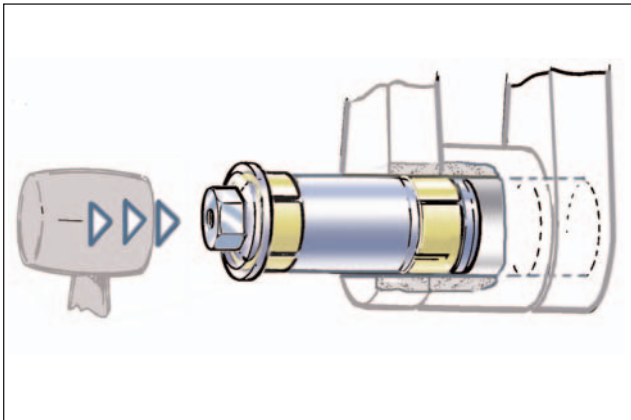

**4.2** Install the Expander System with all its components assembled. DO NOT torque the fastening element, this will facilitate and ease the insertion through the bushing/bearing. Be careful not to damage the threads or tapered parts of the Expander System.

Line up the end of the Expander pin with the outer mounting lug on the side of the fastener side and fasten thereafter the fastening element by hand. If the assembly is turning in the pivot, hold the tension washer with channel lock pliers or similar tool.

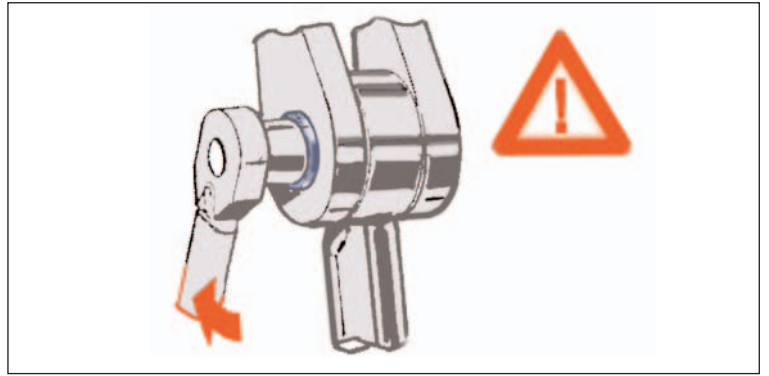

**4.3** Before tightening the System, find the appropriate torque value by looking up the corresponding fastening element in **Table 1**. Refer to the Packing List for the size of the fastening elements. Keep the Packing List for future reference.

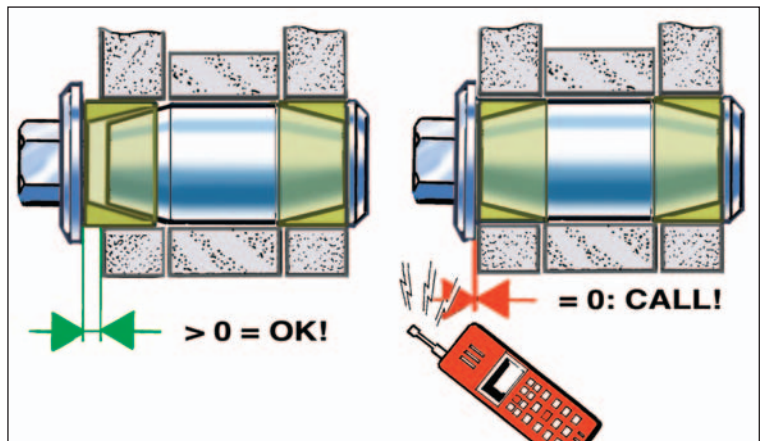

**4.4 IMPORTANT:** The tension washer located between the fastening element and the end of the Expander pin should **NEVER** come in contact with the pivot lug. If this occurs on only one side of the pin, go back to **Section 4.2**. If either tension washer comes in contact with the lug or the end of the Expander pin, the expansion sleeve is incorrectly specified. The System then needs to be fitted with a larger oversize expansion sleeve.

**4.5** Lubricate the pivot using grease with 3-5% molybdenum disulfide before operating the machine. Proper lubrication maintenance will greatly extend the life of the Expander System.

**4.6** Once the initial torque regiment and pivot lubrication have been completed, start the machine and move the unit back and forth. Tighten again until torque wrench "clicks out" on settings. This procedure ensures that the expansion sleeves have properly seated.

# Section 5 - Dismounting Instructions

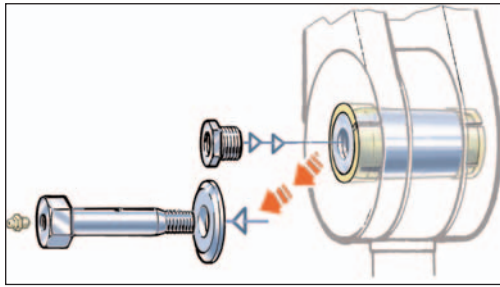

**5.1** Unscrew the fastening element and remove the tension washer. Install the adapter in the threaded part of the Expander pin.

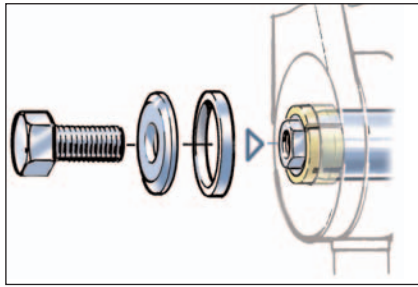

**5.2** Place the dismounting ring between the outer mounting lug and the tension washer, then install the dismounting bolt.

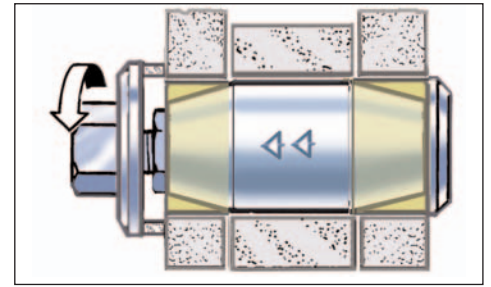

**5.3** Tighten the dismounting bolt to the appropriate torque value in **Table 1**.

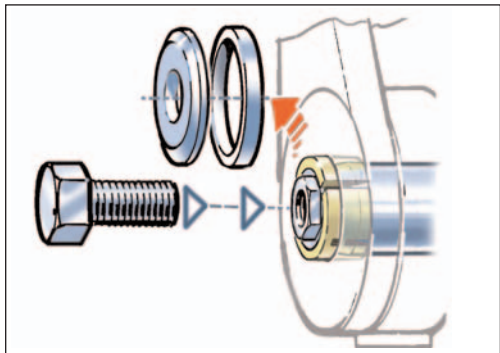

**5.4** Unscrew the dismounting bolt, and remove the dismounting ring and the tension washer. Install and thread the dismounting bolt in the adapter until it "bottoms out".

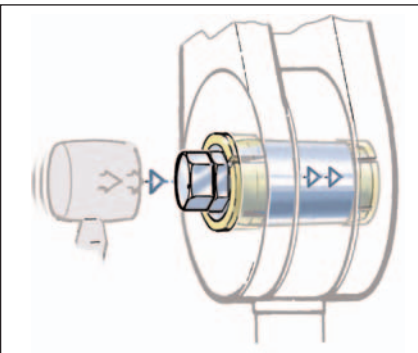

**5.5** Tap on the dismounting bolt until the outer expansion sleeve comes loose.

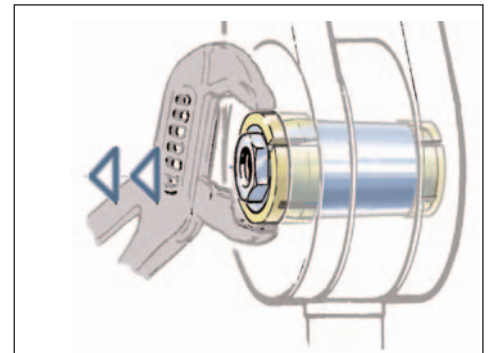

**5.6** Remove the expansion sleeve with channel lock pliers or similar tool, then dismount the remaining parts of the Expander assembly.



## **SWEDEN**

### **Svenska Expander AB**

P.O. Box 217, SE-597 25  
Åtvidaberg  
Sweden  
Phone: +46 - 120 - 299 00  
Fax: +46 - 120 - 355 88

## **USA / CANADA**

### **Expander Americas, Inc.**

P.O. Box 4538,  
Sedona, AZ 86340  
USA  
Phone: 888-935-3884  
Fax: 888-935-3643

## **UNITED KINGDOM**

### **Expander U.K. Limited**

P.O. Box 3965  
CV34 9AJ Warwick  
United Kingdom  
Phone: + 44 - 1453 - 757 077  
Fax: + 44 - 1453 - 759 096

## **GERMANY**

### **Expander Deutschland GmbH**

Zollstrasse 54-56,  
DE-89407 Dillingen-Fristingen  
Germany  
Phone: + 49 - 9071 - 4123  
Fax: + 49 - 9071 - 711 35